

TAG: \_\_\_\_\_

# SUBMITTAL

## Downflow/Horizontal Induced Draft Two Stage Gas Furnace

**TDD2B100A9482A**  
**ADD2B100A9482A**

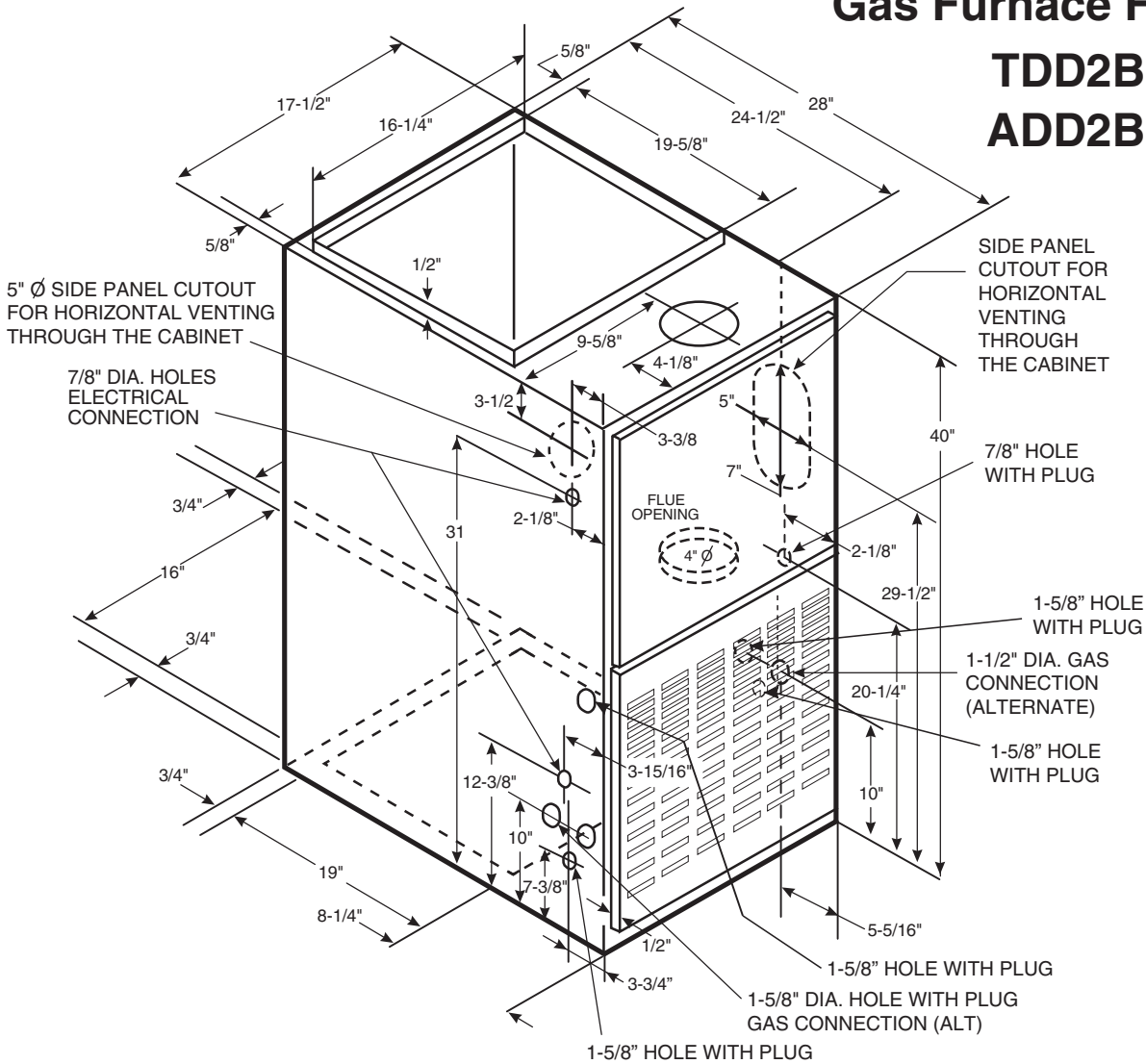

FURNACE AIRFLOW (CFM) VS. EXTERNAL STATIC PRESSURE (IN. W.C.)										
MODEL	SPEED TAP	0.10	0.20	0.30	0.40	0.50	0.60	0.70	0.80	0.90
TDD2B100A9482A ADD2B100A9482A	4 - HIGH - Black	1767	1731	1669	1615	1546	1469	1392	1300	1146
	3 - MED.-HIGH - Blue	1382	1354	1323	1292	1254	1207	1177	1108	1038
	2 - MED.-LOW - Yellow	1130	1138	1115	1085	1054	1015	977	938	877
	1 - LOW - Red	840	831	815	792	762	731	700	654	625

CFM VS. TEMPERATURE RISE							
	CFM (CUBIC FEET PER MINUTE)						
	1200	1300	1400	1500	1600	1700	1800
TDD2B100A9482A, ADD2B100A9482A	62	57	53	49	46	44	41

# General Data ①

TYPE	Downflow/Horizontal
<b>RATINGS 2</b>	
1st Stage Input BTUH	65,000
1st Stage Capacity BTUH (ICS) 3	52,000
2nd Stage Input BTUH	100,000
2nd Stage Capacity BTUH (ICS) 3	79,000
Temp. rise (Min.-Max.) °F.	40 - 70
<b>BLOWER DRIVE</b>	
	DIRECT
Diameter-Width (In.)	10 x 8
No. Used	1
Speeds (No.)	4
CFM vs. in. w.g.	See Fan Performance
Motor HP	1/3
R.P.M.	1075
Volts/Ph/Hz	115/1/60
<b>COMBUSTION FAN - Type</b>	
	Centrifugal
Drive - No. Speeds	Direct - 2
Motor HP - RPM	1/75 - 2708 / 1868
Volts/Ph/Hz	115/1/60
F.L. Amps	0.87 / 0.49
<b>FILTER — Furnished?</b>	
	No
Type Recommended	High Velocity
Hi Vel. (No.-Size-Thk.) Shipped	2 - 16 x 20 - 1in.

<b>VENT COLLAR — Size (in.)</b>	4 Round
<b>HEAT EXCHANGER</b>	
Type-Fired	Alum. Steel
-Unfired	
Gauge (Fired)	20
<b>ORIFICES — Main</b>	
Nat. Gas. Qty. — Drill Size	5 — 45
L.P. Gas Qty. — Drill Size	5 — 56
<b>GAS VALVE</b>	
	Redundant - Two Stage
<b>PILOT SAFETY DEVICE</b>	
Type	Hot Surface Ignition
<b>BURNERS — Type</b>	
	Multiport Inshot
Number	5
<b>POWER CONN. — V/Ph/Hz ④</b>	
	115/1/60
Ampacity (In Amps)	9.2
Max. Overcurrent Protection (amps)	15
<b>PIPE CONN. SIZE (IN.)</b>	
	1/2
<b>DIMENSIONS</b>	
	H x W x D
Crated (In.)	41 - 3/4 x 19-1/2 x 30-1/2
Uncrated (In.)	40 x 17-1/2 x 28-1/2
<b>WEIGHT</b>	
Shipping (Lbs.)/Net (Lbs)	156 / 145

① Central Furnace heating designs are certified to ANSI Z21.47 / CSA 2.3.

② Ratings shown are for elevations up to 2000 feet. For elevations above 2000 feet; Ratings should be reduced at the rate of 4% for each 1000 feet above sea level.

③ Based on U.S. Government Standard Tests.

④ The above wiring specifications are in accordance with National Electrical Code; however, installations must comply with local codes.

## Mechanical Specifications

**NATURAL GAS MODELS** — Central heating furnace designs are certified by the American Gas Association for both natural and L.P. gas. Limit setting and rating data were established and approved under standard rating conditions using American National Standards Institute standards.

**SAFE OPERATION** — The Integrated System Control has solid state devices, which continuously monitor for presence of flame, when the system is in the heating mode of operation. Dual solenoid combination gas valve and regulator provide extra safety.

**QUICK HEATING** — Durable, cycle tested, heavy gauge **aluminized steel heat exchanger** quickly transfers heat to provide warm conditioned air to the structure. **Low energy power vent blower**, to increase efficiency and provide discharge of gas fumes to the outside, allows common venting with hot water heater.

**BURNERS** — Multi-port, in-shot burners will give years of quiet and efficient service. All models can be converted to **L.P. gas** without changing burners.

**INTEGRATED SYSTEM CONTROL** — Exclusively designed operational program provides total control of furnace limit sensors, blowers, gas valve, flame control and includes self diagnostics for ease of service.

**AIR DELIVERY** — The multispeed, direct-drive blower motor, with sufficient airflow range for most heating and cooling requirements, will switch from heating to cooling speeds on demand from room thermostat. The blower door safety switch will prevent or terminate furnace operation when the blower door is removed. (Fan relay and 35VA control transformer is standard).

**STYLING** — **Heavy gauge steel and "wraparound" cabinet construction** is used in the cabinet with baked-on enamel finish for strength and beauty. The heat exchanger section of the cabinet is completely lined with foil-faced fiberglass insulation. This results in quiet and efficient operation due to the excellent acoustical and insulating qualities of fiberglass.

**FEATURES AND GENERAL OPERATION** — These High Efficiency Gas Furnaces employ a Hot Surface Ignition system, which eliminates the waste of a constantly burning pilot. The integrated system control lights the main burners upon a demand for heat from the room thermostat. Complete front service access.

- Low energy power venter.
- Vent proving differential switch.

Since Ingersoll Rand has a policy of continuous product and product data improvement, it reserves the right to change specifications and design without notice.

Technical Literature - Printed in U.S.A.

Ingersoll Rand  
6200 Troup Highway  
Tyler, TX 75707



Library	Unitary
Product Section	Furnaces
Product	Furnace
Model	TDD2
Literature Type	Submittal
Sequence	-
Date	05/15
File No.	TDD2B100-SUB-1B
Supersedes	TDD2B100-SUB-1A