

TAG: _____

SUBMITTAL

TUD2C100A9602A
AUD2C100A9602A

**Upflow/Horizontal
 Gas Furnace - Induced
 Draft - 2 Stage Heat**

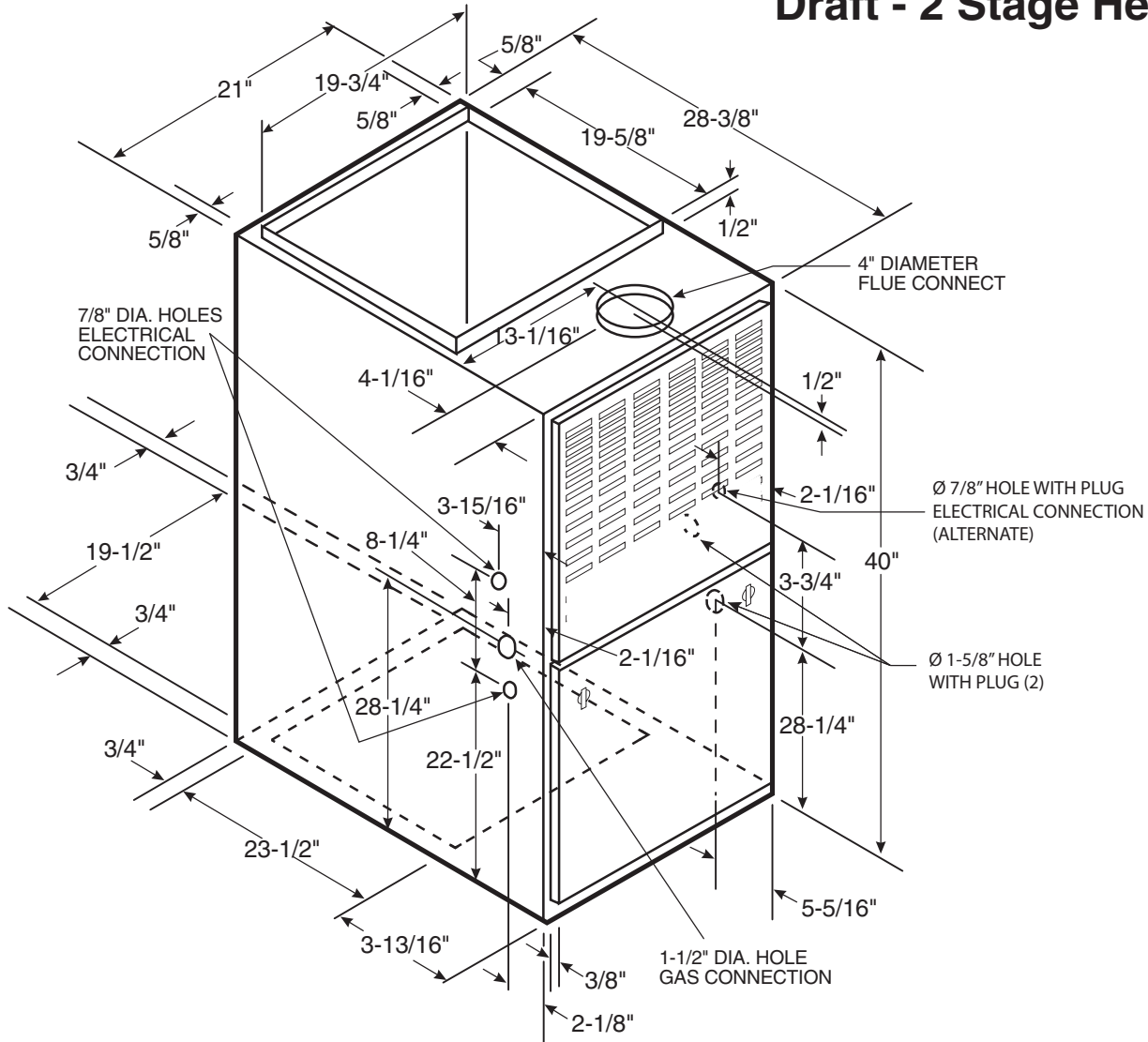

FURNACE AIRFLOW (CFM) VS. EXTERNAL STATIC PRESSURE (IN. W.C.)										
MODEL	SPEED TAP	0.10	0.20	0.30	0.40	0.50	0.60	0.70	0.80	0.90
TUD2C100A9602A AUD2C100A9602A	4 - HIGH - Black	2181	2143	2104	2053	2001	1929	1856	1766	1676
	3 - MED.-HIGH - Blue	1908	1888	1868	1834	1800	1745	1690	1631	1572
	2 - MED.-LOW - Yellow	1621	1609	1597	1582	1567	1533	1498	1438	1377
	1 - LOW - Red	1443	1419	1395	1381	1367	1335	1302	1256	1209

CFM VS. TEMPERATURE RISE													
MODEL	CFM (CUBIC FEET PER MINUTE)												
	1200	1300	1400	1500	1600	1700	1800	1900	2000	2100	2200	2300	2400
TUD2C100A9602A, AUD2C100A9602A	62	57	53	49	46	44	41	39	37	35	34	32	31

General Data ①

TYPE	Upflow/Horizontal
RATINGS 2	
1st Stage Input BTUH	65,000
1st Stage Capacity BTUH (ICS) 3	52,000
2nd Stage Input BTUH	100,000
2nd Stage Capacity BTUH (ICS) 3	80,000
Temp. rise (Min.-Max.) °F.	30 - 60
BLOWER DRIVE	
	DIRECT
Diameter-Width (In.)	11 x 10
No. Used	1
Speeds (No.)	4
CFM vs. in. w.g.	See Fan Performance
Motor HP	1/2
R.P.M.	1075
Volts/Ph/Hz	115/1/60
COMBUSTION FAN - Type	
	Centrifugal
Drive - No. Speeds	Direct - 2
Motor HP - RPM	1/75 - 2708 / 1868
Volts/Ph/Hz	115/1/60
F.L. Amps	0.87 / 0.49
FILTER — Furnished?	
	No
Type Recommended	High Velocity
Hi Vel. (No.-Size-Thk.) Shipped	1 - 20x25 - 1in.

VENT COLLAR — Size (in.)	4 Round
HEAT EXCHANGER	
Type-Fired	Alum. Steel
-Unfired	
Gauge (Fired)	20
ORIFICES — Main	
Nat. Gas. Qty. — Drill Size	5 — 45
L.P. Gas Qty. — Drill Size	5 — 56
GAS VALVE	
	Redundant - Two Stage
PILOT SAFETY DEVICE	
Type	Hot Surface Ignition
BURNERS — Type	
	Multiport Inshot
Number	5
POWER CONN. — V/Ph/Hz ④	
	115/1/60
Ampacity (In Amps)	12.8
Max. Overcurrent Protection (amps)	20
PIPE CONN. SIZE (IN.)	
	1/2
DIMENSIONS	
	H x W x D
Crated (In.)	41-3/4 x 23 x 30-1/2
Uncrated (In.)	40 x 21 x 28-1/2
WEIGHT	
Shipping (Lbs.)/Net (Lbs)	162 / 151

① Central Furnace heating designs are certified to ANSI Z21.47 / CSA 2.3

② Ratings shown are for elevations up to 2000 feet. For elevations above 2000 feet; Ratings should be reduced at the rate of 4% for each 1000 feet above sea level.

③ Based on U.S. Government Standard Tests.

④ The above wiring specifications are in accordance with National Electrical Code; however, installations must comply with local codes.

Mechanical Specifications

NATURAL GAS MODELS— Central heating furnace designs are certified to ANSI Z21.47 / CSA 2.3 for both natural and L.P. gas. Limit setting and rating data were established and approved under standard rating conditions using American National Standards Institute standards.

SAFE OPERATION— The Integrated System Control has solid state devices, which continuously monitor for presence of flame, when the system is in the heating mode of operation. Dual solenoid combination gas valve and regulator provide extra safety.

QUICK HEATING— Durable, cycle tested, heavy gauge **aluminized steel heat exchanger** quickly transfers heat to provide warm conditioned air to the structure. **Low energy power vent blower**, to increase efficiency and provide discharge of gas fumes to the outside, allows common venting with hot water heater.

BURNERS — Multi-port, in-shot burners

will give years of quiet and efficient service. All models can be converted to **L.P. gas** without changing burners.

INTEGRATED SYSTEM CONTROL— Exclusively designed operational program provides total control of furnace limit sensors, blowers, gas valve, flame control and includes self diagnostics for ease of service.

AIR DELIVERY — The multispeed, direct-drive blower motor, with sufficient airflow range for most heating and cooling requirements, will switch from heating to cooling speeds on demand from room thermostat. The blower door safety switch will prevent or terminate furnace operation when the blower door is removed. (Fan relay and 35VA control transformer is standard).

STYLING — **Heavy gauge steel and "wraparound" cabinet construction** is

used in the cabinet with baked-on enamel finish for strength and beauty. The heat exchanger section of the cabinet is completely lined with foil-faced fiberglass insulation. This results in quiet and efficient operation due to the excellent acoustical and insulating qualities of fiberglass.

FEATURES AND GENERAL OPERATION — These High Efficiency Gas Furnaces employ a Hot Surface Ignition system, which eliminates the waste of a constantly burning pilot. The integrated system control lights the main burners upon a demand for heat from the room thermostat. Complete front service access.

- Low energy power venter.
- Vent proving differential switch.

Since Ingersoll Rand has a policy of continuous product and product data improvement, it reserves the right to change specifications and design without notice.

Technical Literature - Printed in U.S.A.

Ingersoll Rand
6200 Troup Highway
Tyler, TX 75707



Library	Unitary
Product Section	Furnaces
Product	Furnace
Model	TUD2
Literature Type	Submittal
Sequence	-
Date	04/15
File No.	TUD2C100-SUB-2B
Supersedes	TUD2C100-SUB-2A