

TAG: _____

SUBMITTAL

TUHMD120ACV5VB
AUHMD120ACV5VB

**Communicating
Upflow/Horizontal Left
Direct/Non-Direct Vent
Modulating Gas Furnace
with Variable Speed Inducer**

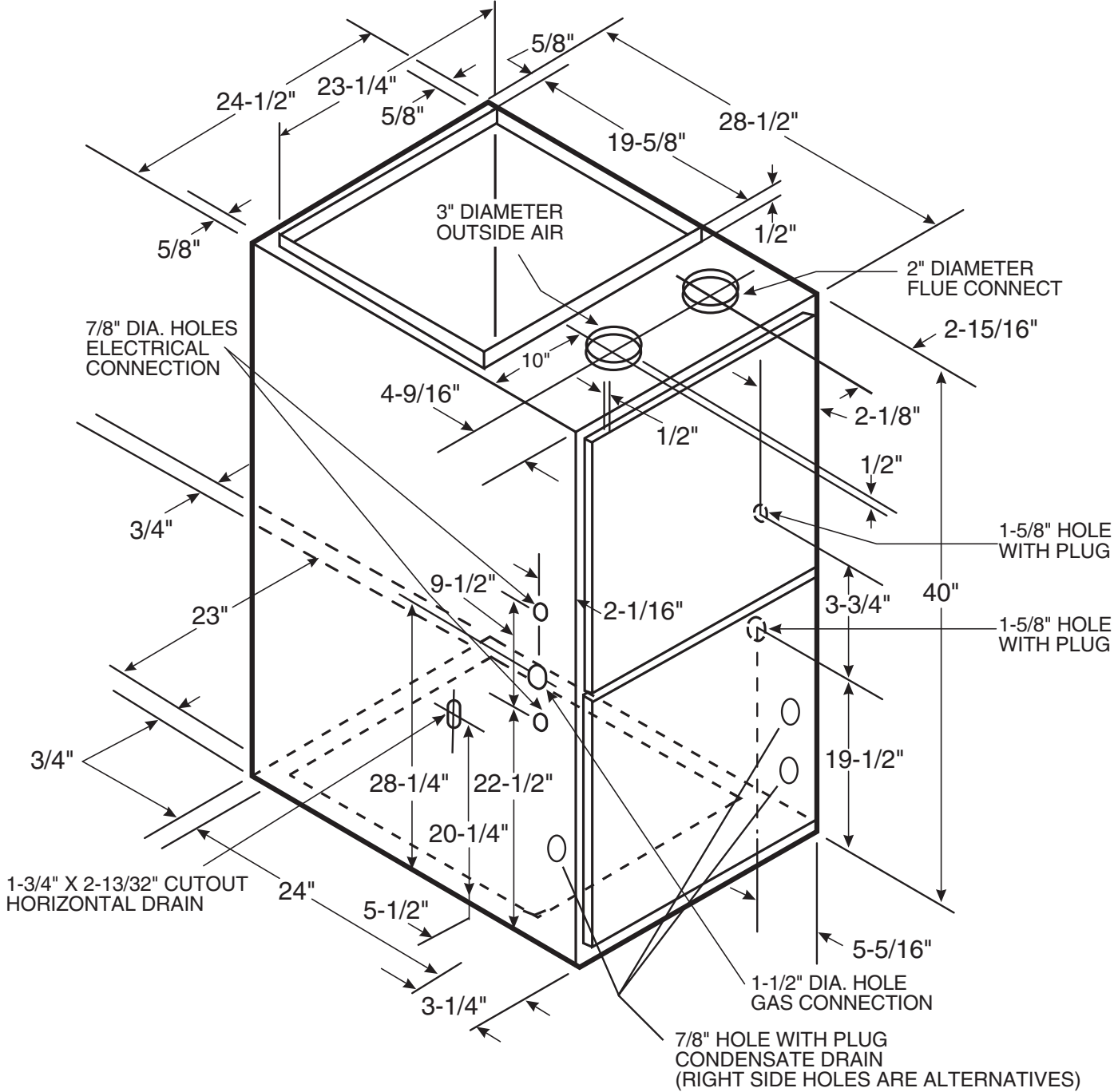

TUHMD120 Airflow - Heating

TUHMD120 Airflow - Cooling

UHMD120ACV5VB Furnace Heating Airflow (CFM) and Power (Watts) vs. External Static Pressure With Filter								
Heating	Airflow Setting	Target Airflow (See Note 5)	External Static Pressure					
			0.1	0.3	0.5	0.7	0.9	
45% (low) Heat	Low	748	CFM	728	758	785	805	819
			Temp. Rise	62	59	57	56	55
			Watts	119	107	102	94	108
	Medium Low	788	CFM	769	797	822	840	853
			Temp. Rise	58	56	54	53	53
			Watts	113	107	111	113	133
	Medium**	832	CFM	813	841	864	880	890
			Temp. Rise	55	53	52	51	50
			Watts	108	107	122	135	160
	High	880	CFM	863	889	910	923	930
			Temp. Rise	52	50	49	49	48
			Watts	104	108	135	160	191
65% (medium) Heat	Low	1224	CFM	1213	1232	1237	1232	1220
			Temp. Rise	60	60	59	60	60
			Watts	131	160	253	345	405
	Medium Low	1289	CFM	1279	1297	1299	1290	1274
			Temp. Rise	57	57	56	57	58
			Watts	147	178	281	382	445
	Medium**	1361	CFM	1353	1369	1367	1355	1335
			Temp. Rise	54	54	54	54	55
			Watts	168	201	313	423	489
	High	1440	CFM	1434	1448	1443	1426	1402
			Temp. Rise	51	51	51	51	52
			Watts	197	229	352	469	538
100% (high) Heat	Low	1700	CFM	1699	1707	1690	1659	1621
			Temp. Rise	60	60	60	61	63
			Watts	325	349	495	628	698
	Medium Low	1790	CFM	1790	1797	1775	1740	1696
			Temp. Rise	57	57	57	59	60
			Watts	382	400	551	685	752
	Medium**	1890	CFM	1892	1896	1870	1830	1781
			Temp. Rise	54	54	54	56	57
			Watts	453	462	616	750	813
	High	2000	CFM	2004	2006	1975	1929	1873
			Temp. Rise	51	51	52	53	54
			Watts	540	538	694	822	880

Notes:
 1. * First letter may be "A" or "T".
 2. ** Factory setting.
 3. Continuous Fan Setting: Heating or cooling airflow is approximately 50% of selected cooling value.
 4. LOW 350 cfm/ton is recommended for variable speed application for COMFORT & HUMID CLIMATE setting; NORMAL is 400 cfm/ton; HIGH 450 cfm/ton is for DRY CLIMATE setting.
 5. Target airflow is field selectable for third stage heating. Target airflow for first and second stage heating are percentages of third stage target and are not field selectable.

UHMD120ACV5VB Furnace Cooling Airflow (CFM) and Power (Watts) vs. External Static Pressure With Filter								
Cooling	Unit Outdoor	Airflow Setting	External Static Pressure					
			0.1	0.3	0.5	0.7	0.9	
Cooling	3.5	290 CFM/ton	CFM	1000	1024	1028	1022	1011
			Watts	122	168	209	251	300
		310 CFM/ton	CFM	1072	1094	1097	1089	1076
			Watts	140	188	234	281	331
		330 CFM/ton	CFM	1143	1164	1165	1157	1141
			Watts	160	211	261	313	364
		350 CFM/ton	CFM	1214	1233	1234	1224	1207
			Watts	182	236	291	347	400
		370 CFM/ton	CFM	1286	1303	1302	1291	1272
			Watts	207	264	323	384	438
		400 CFM/ton	CFM	1393	1408	1405	1392	1370
			Watts	250	311	377	444	500
	430 CFM/ton	CFM	1500	1513	1508	1492	1468	
		Watts	300	365	437	509	565	
	450 CFM/ton	CFM	1571	1582	1576	1559	1533	
		Watts	337	406	481	555	611	
	4	290 CFM/ton	CFM	1148	1169	1170	1161	1146
			Watts	161	213	263	315	367
		310 CFM/ton	CFM	1230	1248	1248	1238	1221
			Watts	187	242	297	355	408
		330 CFM/ton	CFM	1311	1328	1327	1315	1295
			Watts	217	274	335	398	452
		350 CFM/ton	CFM	1393	1408	1405	1392	1370
			Watts	250	311	377	444	500
		370 CFM/ton	CFM	1474	1488	1483	1468	1445
			Watts	287	352	422	493	549
		400 CFM/ton	CFM	1597	1607	1601	1583	1556
			Watts	352	421	497	572	628
	430 CFM/ton	CFM	1719	1727	1718	1699	1668	
		Watts	427	503	581	655	711	
	450 CFM/ton	CFM	1801	1807	1797	1775	1743	
		Watts	483	563	642	712	768	
	5	290 CFM/ton	CFM	1444	1458	1454	1440	1417
			Watts	273	336	405	475	530
		310 CFM/ton	CFM	1546	1557	1552	1535	1510
			Watts	324	391	465	538	594
330 CFM/ton		CFM	1648	1657	1650	1631	1603	
		Watts	381	454	531	606	662	
350 CFM/ton		CFM	1750	1757	1748	1727	1696	
		Watts	447	525	603	676	732	
370 CFM/ton		CFM	1852	1857	1845	1823	1790	
		Watts	522	604	682	749	804	
400 CFM/ton		CFM	2004	2006	1992	1967	1947	
		Watts	651	742	811	863	966	
430 CFM/ton	CFM	2157	2156	2140	2050	1947		
	Watts	803	902	966	966	966		
450 CFM/ton	CFM	2259	2255	2140	2050	1947		
	Watts	966	966	966	966	966		

Notes:
 1. * First letter may be "A" or "T".
 2. ^ Letter may be "A" through "Z"
 3. ** Factory setting.
 4. Continuous Fan Setting: Heating or cooling airflow is approximately 50% of selected cooling value.
 5. LOW 350 cfm/ton is recommended for variable speed application for COMFORT & HUMID CLIMATE setting; NORMAL is 400 cfm/ton; HIGH 450 cfm/ton is for DRY CLIMATE setting.

NOTE:
 CONTINUOUS fan mode during COOLING operation may not be appropriate in humid climates. If the indoor air exceeds 60% relative humidity or simply feels uncomfortably humid, it is recommended that the fan only be used in the AUTO mode.

Airflow Adjustment

Check inlet and outlet air temperatures to make sure they are within the range specified on the Furnace rating nameplate. If the airflow needs to be increased or decreased, see the Airflow Label on the Furnace or the unit's Service Facts for information on changing the speed of the Blower Motor for your specific model. Blower speed changes are made on the User Interface.

INDOOR BLOWER TIMING

Heating: The Integrated Furnace Control module controls the Indoor Blower. The Blower start is fixed at 45 seconds after ignition. The FAN-OFF period is field selectable by the User Interface at 60, 100, 140, or 180 seconds. The factory setting is 100 seconds.

MODEL	TUHMD120ACV5VB ⑥ AUHMD120ACV5VB
TYPE	Upflow/Horizontal Left
RATINGS ②	
45% (low) heat Input BTUH	54,000
45% (low) heat Capacity BTUH (ICS) ③	52,000
100% (high) heat Input BTUH	120,000
100% (high) heat Capacity BTUH (ICS) ③⑥	114,000
Temp. rise (Min.-Max.) °F.	40 - 70
AFUE (Upflow / Horizontal)	97.0 / 96.2
BLOWER DRIVE	
Diameter - Width (In.)	DIRECT 10 x 10
No. Used	1
Speeds (No.)	Variable
CFM vs. in. w.g.	See Fan Performance Table
Motor HP	1
R.P.M.	Variable
Volts/Ph/Hz	115/1/60
FLA	9.9
COMBUSTION FAN - Type	
Drive - No. Speeds	Centrifugal Direct - Variable
Motor HP - RPM	1/50 - 5000
Volts/Ph/Hz	115/3/60
FLA	1.0
FILTER — Furnished?	
Type Recommended	Yes High Velocity
Hi Vel. (No.-Size-Thk.)	1 - 24x25 - 1 in.
VENT — Size (in.)	
	3 Round
HEAT EXCHANGER	
Type -Fired	Aluminized Steel - Type I
-Unfired	
Gauge (Fired)	20
ORIFICES — Main	
Nat. Gas. Qty. — Drill Size	6 — 45
L.P. Gas Qty. — Drill Size ⑤	6 — 56
GAS VALVE	
	Redundant - Three Stage
PILOT SAFETY DEVICE	
Type	Hot Surface Igniter
BURNERS — Type	
Number	Multiport Inshot 6
POWER CONN. — V/Ph/Hz ④	
Ampacity (In Amps)	115/1/60 13.5
Max. Overcurrent Protection (Amps)	15
PIPE CONN. SIZE (IN.)	
	1/2
DIMENSIONS	
Crated (In.)	H x W x D 41-3/4 x 26-1/2 x 30-1/2
WEIGHT	
Shipping (Lbs.)/Net (Lbs)	206 / 193

① Central Furnace heating designs are certified to ANSI Z21.47 / CSA 2.3.

② For U.S. applications, above input ratings (BTUH) are up to 2,000 feet, derate 4% per 1,000 feet for elevations above 2,000 feet above sea level.
For Canadian applications, above input ratings (BTUH) are up to 4,500 feet, derate 4% per 1,000 feet for elevations above 4,500 feet above sea level.

③ Based on U.S. government standard tests.

④ The above wiring specifications are in accordance with National Electrical Code; however, installations must comply with local codes.

⑤ Furnace ships in natural gas configuration. The LP conversion kit used with the modulating furnace is BAYLPSS220B or BAYLPKT220B.

⑥ Energy Star

Mechanical Specifications

MODULATING OPERATION

The modulating gas valve provides longer heating cycles for more consistent heating comfort. Modulates from 40% to 100% in less than 1% increments of the furnace's heating capacity saving energy, while at the same time providing maximum homeowner comfort.

COMMUNICATING MODE

Furnace is shipped ready to be connected in communicating mode using three wire hook-up using A/TCONT900 comfort control.

ALTERNATE 24V MODE

Furnace is field configurable to 24V non-communicating mode.

COMFORT CONTROL

Communicating furnace design, offers plug and play – walk away installation. Assures the entire heating and air conditioning system is set up in the proper modes to optimize the engineered performance of the matched system installed. The furnace can also be connected in 24V mode.

NATURAL GAS MODELS

Central Heating furnace designs are certified by the American Gas Association for both natural and L.P. gas. Limit setting and rating data were established and approved under standard rating conditions using American National Standards Institute standards.

ENERGY EFFICIENT OPERATION

Furnace is certified to leak 2% or less of nominal air conditioning CFM delivered when pressurized to .5" water column with all inlets, outlets, and drains sealed.

SAFE OPERATION

The Integrated System Control has solid state devices, which continuously monitor for presence of flame, when the system is in the heating mode of operation. Dual solenoid combination gas valve and regulator provide additional safety.

QUICK HEATING

Durable, cycle tested, heavy gauge aluminumized steel heat exchanger quickly transfers heat to provide warm conditioned air to the structure. Low energy power vent blower, to increase efficiency and provide a positive discharge of gas fumes to the outside.

BURNERS

Multi-port In-shot burners will give years of quiet and efficient service. All models can be converted to L.P. gas without changing burners.

INTEGRATED SYSTEM CONTROL

Exclusively designed operational program provides total control of furnace limit sensors, blowers, gas valve, flame control and includes self diagnostics for ease of service. Also contains connection points for EAC and Humidifier.

AIR DELIVERY

The variable speed blower motor has sufficient airflow for most heating and cooling requirements and will switch from heating to cooling speeds on demand from room thermostat. The blower door safety switch will prevent or terminate furnace operation when the blower door is removed.

SECONDARY HEAT EXCHANGER

The furnace has a special type 29-4C™ stainless steel secondary heat exchanger to reclaim heat from flue gases which would normally be lost.

STYLING

Heavy gauge steel and "wrap-around" cabinet construction is used in the cabinet with baked-on enamel finish for strength and beauty. The heat exchanger section of the cabinet is completely lined with foil faced fiberglass insulation. This results in quiet and efficient operation due to the excellent acoustical and insulating qualities of fiberglass. Built-in bottom pan and alternate bottom, left or right side return air connection provision.

FEATURES AND GENERAL OPERATION

The High Efficiency Gas Furnaces utilize an Adaptive Heat Up Silicon Nitride Hot Surface Ignition system, which eliminates the waste of a constant burning pilot. The integrated system control lights the main burners upon a demand for heat from the room thermostat. Complete front service access.

- a. Low energy power venter
- b. Vent proving pressure switch.

Ingersoll Rand has a policy of continuous product and product data improvement and it reserves the right to change specifications and design without notice.

Ingersoll Rand
6200 Troup Highway
Tyler, TX 75711-9010

