

Submittal

Downflow Two Stage Condensing Gas Fired Furnace 100,000 BTUH

Downflow Only
S9V2C100D4PSBA

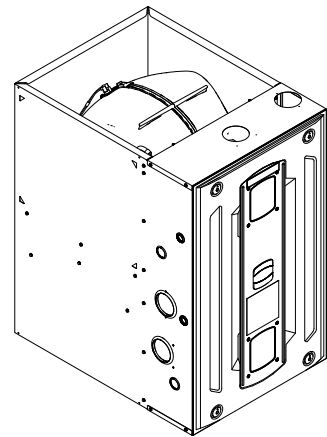

Note: Graphics in this document are for representation only. Actual model may differ in appearance.

TAG: _____

▲ SAFETY WARNING

Only qualified personnel should install and service the equipment. The installation, starting up, and servicing of heating, ventilating, and air-conditioning equipment can be hazardous and requires specific knowledge and training. Improperly installed, adjusted or altered equipment by an unqualified person could result in death or serious injury. When working on the equipment, observe all precautions in the literature and on the tags, stickers, and labels that are attached to the equipment.

March 2017

S9V2C100D4-SUB-1B-EN

 Ingersoll Rand.

Outline Drawings

Downflow Furnace C Size Cabinet

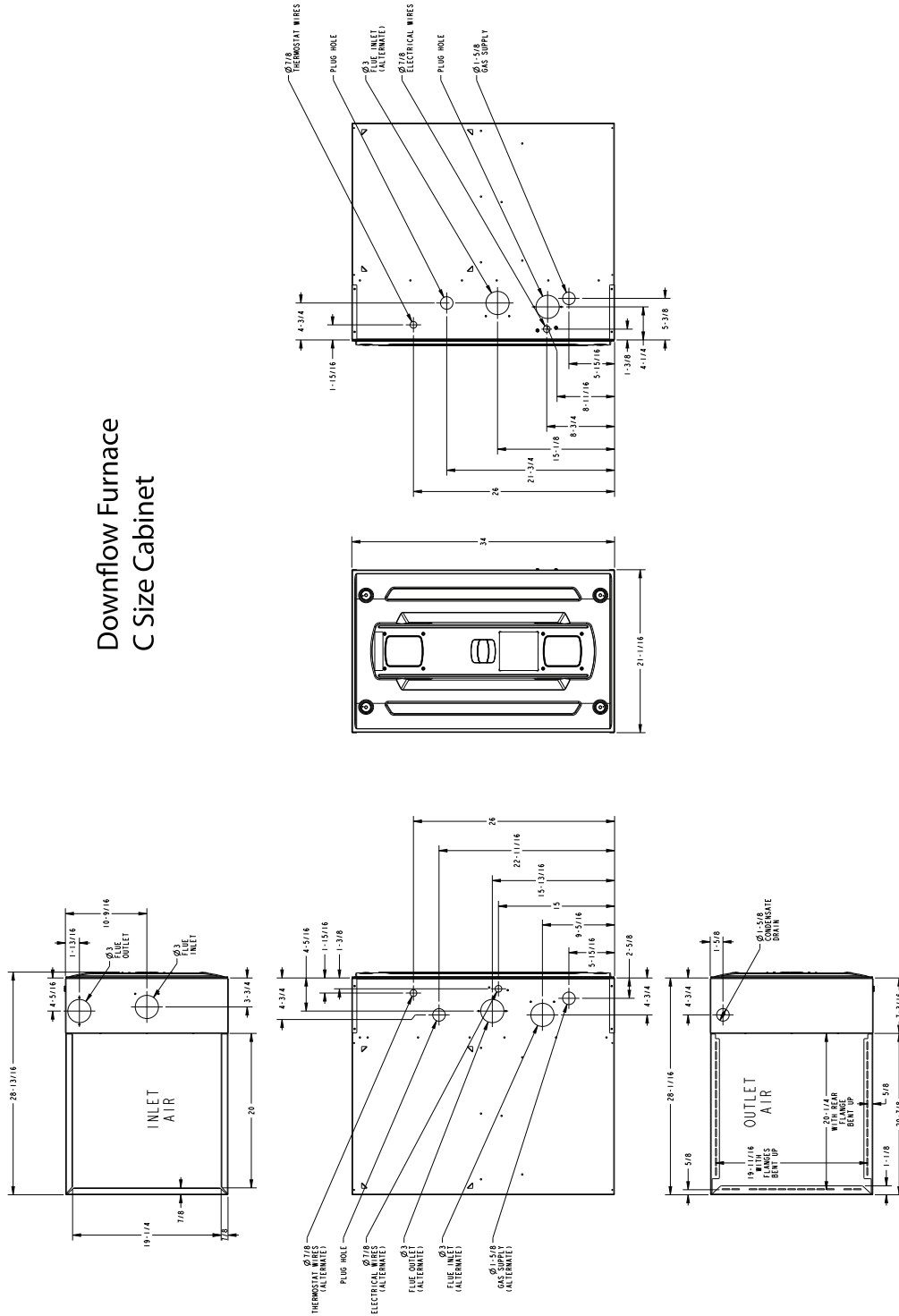

Product Specification

MODEL	S9V2C100D4PSBA
TYPE	Downflow
RATINGS (a)	
1st Stage Input BTUH (ICS)	65,000
1st Stage Capacity BTUH	63,050
2nd Stage Input BTUH	100,000
2nd Stage Capacity BTUH (ICS) (b)(c)	97,000
1st Stage Temp. Rise (Min.-Max.)	25 - 55
2nd Stage Temp. Rise (Min.-Max.)	35 - 65
AFUE (%)	96.0
BLOWER DRIVE	DIRECT
Diameter — Width (In.)	11 X 10
No. Used	1
Speeds (No.)	Variable
CFM vs. in. w.g.	See Fan Performance Table
Motor HP	3/4
RPM	Variable
Volts/Ph/Hz	120 / 1 / 60
FLA	8.0
COMBUSTION FAN — Type	Centrifugal
Drive — No. Speeds	Direct - 2
Motor HP — RPM	3300/2600
Volts/Ph/Hz	120 / 1 / 60
FLA	0.66
FILTER — Furnished?	No
Type recommended	High Velocity
Hi Vel. (No.-Size-Thk.)	2 — 16x20 — 1 in.
VENT PIPE DIAMETER — Min (in.) (d) (e)	2 Round
HEAT EXCHANGER	

MODEL	S9V2C100D4PSBA
Type — Fired	409 Stainless Steel
— Unfired	29-4C Stainless Steel
Gauge (Fired)	20
ORIFICES — Main	
Nat. Gas Qty. — Drill Size	5 - 45
LP Gas Qty. — Drill Size	5- 56
GAS VALVE	Redundant - Two Stage
PILOT SAFETY DEVICE	
Type	120 V SiNi Igniter
BURNERS — Type	Multiport Inshot
Number	5
POWER CONN. — V/Ph/Hz (f)	120 / 1 / 60
Ampacity (In Amps)	10.8
Max. Overcurrent Protection (Amps)	15
PIPE CONN. SIZE (in.)	1/2
DIMENSIONS	H x W x D
Uncrated (In.)	34 x 21 x 28-3/4
Crated (In.)	35-1/2 x 23 x 30-7/8
WEIGHT	
Shipping (Lbs.)/Net (Lbs.)	154/144

(a) For U.S. applications, above input ratings (BTUH) are up to 2,000 feet, derate 4% per 1,000 feet for elevations above 2,000 feet above sea level. For Canadian applications, above input ratings (BTUH) are up to 4,500 feet, derate 4% per 1,000 feet for elevations above 4,500 feet above sea level.

(b) Central Furnace heating designs are certified to ANSI Z21.47 / CSA 2.3.

(c) Based on U.S. government standard tests.

(d) Refer to the Vent Length Table in the Installer's Guide.

(e) All S9V2 furnace models have a vent outlet diameter that equals 2 in.

(f) The above wiring specifications are in accordance with National Electrical Code; however, installations must comply with local codes.

Heating and Cooling Airflow Tables

S9V2C100D4PSBA

Table 1. S9V2C100D4PSBA Heating Airflow

S9V2C100D4PSBA Furnace Heating Airflow (CFM) and Power (Watts) vs. External Static Pressure with Filter								
				1st Stage Capacity = 63,050 2nd Stage Capacity = 97,000				
Heating	Airflow Setting	Target Airflow		External Static Pressure				
				0.1	0.3	0.5	0.7	0.9
Heating 1st Stage	Low	1080	CFM	1068	1048	1029	1009	989
			Temp. Rise	55	57	60	63	66
			Watts	101	151	201	251	301
	Medium Low	1166	CFM	1158	1113	1068	1023	978
			Temp. Rise	51	53	55	57	59
			Watts	115	172	229	285	342
	Medium ^(a)	1318	CFM	1326	1272	1218	1164	1111
			Temp. Rise	46	48	50	51	53
			Watts	153	206	259	312	365
	High	1361	CFM	1312	1270	1229	1188	1147
			Temp. Rise	46	47	47	48	49
			Watts	166	221	276	331	387
Heating 2nd Stage	Low	1500	CFM	1514	1478	1441	1404	1367
			Temp. Rise	58	60	61	63	64
			Watts	223	297	370	443	516
	Medium Low	1620	CFM	1620	1588	1556	1523	1491
			Temp. Rise	55	56	57	58	59
			Watts	276	345	415	484	553
	Medium ^(a)	1830	CFM	1768	1746	1724	1702	1620
			Temp. Rise	50	51	52	53	53
			Watts	372	446	520	594	668
	High	1890	CFM	1810	1783	1756	1729	1702
			Temp. Rise	49	50	51	52	52
			Watts	405	476	548	677	695

^(a) Factory Setting.

S9V2C100U4PSBA / S9V2C100D4PSBA

Table 2. S9V2C100U4PSBA / S9V2C100D4PSBA Cooling Airflow

S9V2C100U4PSBA / S9V2C100D4PSBA Furnace Cooling Airflow (CFM) and Power (Watts) vs. External Static Pressure with Filter										
Cooling	Unit Outdoor	Airflow Setting (CFM/ton)		External Static Pressure						
				0.1	0.3	0.5	0.7	0.9		
Cooling	2.5 Ton	Cooling 450 CFM/Ton	CFM	1125	1125	1125	1125	1125		
			Watts	123	178	236	296	360		
		Cooling 420 CFM/Ton	CFM	1050	1050	1050	1050	1050		
			Watts	104	156	210	268	329		
		Cooling 400 CFM/Ton	CFM	1000	1000	1000	1000	1000		
			Watts	93	142	195	251	309		
		Cooling 370 CFM/Ton	CFM	925	925	925	925	925		
			Watts	77	123	173	226	282		
		Cooling 350 CFM/Ton	CFM	875	875	875	875	875		
			Watts	68	112	160	211	265		
		Cooling 330 CFM/Ton	CFM	825	825	825	825	825		
			Watts	60	102	147	196	249		
		Cooling 310 CFM/Ton	CFM	775	775	775	775	775		
			Watts	52	92	135	183	234		
		Cooling 290 CFM/Ton	CFM	725	725	725	725	725		
			Watts	45	83	125	170	220		
		Cooling	3.0 Ton	Cooling 450 CFM/Ton	CFM	1350	1350	1350	1350	1350
					Watts	194	259	326	396	468
Cooling 420 CFM/Ton	CFM			1260	1260	1260	1260	1260		
	Watts			163	224	287	353	422		
Cooling 400 CFM/Ton	CFM			1200	1200	1200	1200	1200		
	Watts			144	202	263	327	393		
Cooling 370 CFM/Ton	CFM			1110	1110	1110	1110	1110		
	Watts			119	173	231	291	354		
Cooling 350 CFM/Ton	CFM			1050	1050	1050	1050	1050		
	Watts			104	156	210	268	329		
Cooling 330 CFM/Ton	CFM			990	990	990	990	990		
	Watts			91	140	192	247	306		
Cooling 310 CFM/Ton	CFM			930	930	930	930	930		
	Watts			78	125	174	228	284		
Cooling 290 CFM/Ton	CFM			870	870	870	870	870		
	Watts			67	111	158	209	264		
Cooling	3.5 Ton			Cooling 450 CFM/Ton	CFM	1575	1575	1575	1575	1575
					Watts	289	363	440	519	600
		Cooling 420 CFM/Ton	CFM	1470	1470	1470	1470	1470		

Heating and Cooling Airflow Tables

Table 2. S9V2C100U4PSBA / S9V2C100D4PSBA Cooling Airflow (continued)

S9V2C100U4PSBA / S9V2C100D4PSBA Furnace Cooling Airflow (CFM) and Power (Watts) vs. External Static Pressure with Filter										
Cooling	Unit Outdoor	Airflow Setting (CFM/ton)		External Static Pressure						
				0.1	0.3	0.5	0.7	0.9		
			Watts	241	311	383	458	535		
		Cooling 400 CFM/Ton	CFM	1400	1400	1400	1400	1400		
			Watts	213	280	349	421	495		
		Cooling 370 CFM/Ton	CFM	1295	1295	1295	1295	1295		
			Watts	175	237	302	369	439		
		Cooling 350 CFM/Ton	CFM	1225	1225	1225	1225	1225		
			Watts	152	211	273	338	405		
		Cooling 330 CFM/Ton	CFM	1155	1155	1155	1155	1155		
			Watts	131	187	247	308	373		
		Cooling 310 CFM/Ton	CFM	1085	1085	1085	1085	1085		
			Watts	113	166	222	281	343		
		Cooling 290 CFM/Ton	CFM	1015	1015	1015	1015	1015		
			Watts	96	146	199	256	315		
		Cooling	4.0 Ton ^(a)	Cooling 450 CFM/Ton	CFM	1800	1800	1800	1800	1714
					Watts	410	494	580	669	695
				Cooling 420 CFM/Ton	CFM	1680	1680	1680	1680	1680
Watts	342				420	502	585	671		
Cooling 400 CFM/Ton	CFM			1600	1600	1600	1600	1600		
	Watts			301	376	454	534	617		
Cooling 370 CFM/Ton	CFM			1480	1480	1480	1480	1480		
	Watts			246	316	388	464	541		
Cooling 350 CFM/Ton ^(a)	CFM			1400	1400	1400	1400	1400		
	Watts			213	280	349	421	495		
Cooling 330 CFM/Ton	CFM			1320	1320	1320	1320	1320		
	Watts			183	247	313	381	452		
Cooling 310 CFM/Ton	CFM			1240	1240	1240	1240	1240		
	Watts			157	216	279	344	412		
Cooling 290 CFM/Ton	CFM			1160	1160	1160	1160	1160		
	Watts			133	189	248	310	375		

^(a) Factory Setting

General Features

NATURAL GAS MODELS

Central Heating furnace designs are certified by the American Gas Association for both natural and L.P. gas. Limit setting and rating data were established and approved under standard rating conditions using American National Standards Institute standards.

SAFE OPERATION

The Integrated System Control is a solid state device which continuously monitors for presence of flame when the system is in the heating mode of operation. Dual solenoid combination gas valve and regulator provide additional safety.

QUICK HEATING

Durable, cycle tested, heavy gauge **tubular stainless steel primary heat exchanger** quickly transfers heat to provide warm conditioned air to the structure. **Low energy power vent blower**, to increase efficiency and provide a positive discharge of gas fumes to the outside.

BURNERS

Multiport Inshot burners will give years of quiet and efficient service. All models can be converted to **L.P. gas** with LP conversion kit.

INTEGRATED SYSTEM CONTROL

Exclusively designed operational program provides total control of furnace limit sensors, blowers, gas valve, flame control and includes self diagnostics for ease of service. Also contains dry contacts for EAC and HUM.

ENERGY EFFICIENT OPERATION

Furnace is certified by the manufacturer to leak 1% or less of nominal air conditioning CFM delivered when pressurized to .5" water column with all inlets, outlets, and drains sealed.

AIR DELIVERY

The variable speed blower motor has sufficient airflow for most heating and cooling requirements and will switch from heating to cooling speeds on demand from room thermostat.

SECONDARY HEAT EXCHANGER

The S-Series furnace has a special type 29- 4C™ stainless steel secondary heat exchanger to reclaim heat from flue gases which would normally be lost.

STYLING

Heavy gauge steel and "wrap-around" cabinet construction is used in the cabinet with baked-on enamel finish for strength and beauty. Every orientation has at least two venting options. There are no knockouts on cabinet.

FEATURES AND GENERAL OPERATION

The S-Series furnace utilizes a Silicon Nitride Hot Surface Ignition system, which eliminates the waste of a constant burning pilot. The integrated system control lights the main burners upon a demand for heat from the room thermostat. Complete front service access.

- a. Low energy power venter
- b. Vent proving pressure switches.

Features and Benefits

96.0% AFUE ACROSS ALL MODELS

Meets utility rebates

Lowers utility bills

ELECTRICALLY EFFICIENT

Efficient airflow design reduces electrical energy use

34 INCH TALL

Lighter, easier to move and fit into tight spaces like short basements or tight closets

Works great with larger, high-efficiency coils

No knockouts

3-WAY MULTI-POISE / DEDICATED DOWNFLOW

9 SKU's — Upflow / Horizontal Left / Horizontal Right

7 SKU's — Downflow

Added application flexibility and reduction in specification errors

AIRFLOW

At least 400 CFM/ton at 0.5 in. H₂O external static pressure; setup airflow options down to 290 CFM/ton

REGULATORY

All models are air tight; 1% or less air leakage as per ASHRAE 193

Open vestibule design provides a full 34" high open vestibule

DIMENSIONS

Widths are industry standard: 17.5", 21", and 24.5"

Depth remains approximately 28"

Cabinet will be compatible with industry standard coils, as well as, other accessories

INTEGRATED FURNACE CONTROL

Setup / Status / Diagnostics / Digital Display

No dip switches

Last six errors stored

Dry contact EAC and HUM connections

All Molex connections; no spade terminals

Low voltage labeled above and below

Rain shield over IFC keeps condensate off the control

TUBULAR STAINLESS STEEL PRIMARY HEAT EXCHANGER

29-4C STAINLESS STEEL SECONDARY HEAT EXCHANGER

Stainless steel is a more durable, corrosive-resistant material than aluminized steel

Integrated rail system for easy access if required

Reduces or eliminates need for baffles

VORTICA II BLOWER, DESIGNED EXCLUSIVELY FOR THE S-SERIES FURNACE

Improved airflow efficiency

Durable, easy to clean, two piece housing

Single piece belly band/ motor arm assembly

Blower deck has full-length rails for easy removal and replacement, regardless of poise

THREE-WAY MULTI-POISE (UPFLOW, HORIZONTAL LEFT AND RIGHT) PLUS DEDICATED DOWNFLOW

Easier to specify

Shipped ready to install (no kits required)

Every model has at least two venting options

When in horizontal, trap extends only about 2"

Barbed fitting on trap at hose connection and on cabinet transition for hose has barbed fitting and clamps at both ends for leak resistance.

Vent table improvements including longer vent lengths; 2" pipe can be used up to 100K



Ingersoll Rand (NYSE: IR) advances the quality of life by creating comfortable, sustainable and efficient environments. Our people and our family of brands — including Club Car®, Ingersoll Rand®, Thermo King® and Trane® — work together to enhance the quality and comfort of air in homes and buildings; transport and protect food and perishables; and increase industrial productivity and efficiency. We are a global business committed to a world of sustainable progress and enduring results.



ingersollrand.com



Ingersoll Rand has a policy of continuous product and product data improvements and reserves the right to change design and specifications without notice.
We are committed to using environmentally conscious print practices.